

320,000 AMP PANEL PROTECTION

EFI Electronics Titan 320M delivers specification grade performance for service entrance or critical branch panel applications. This multi-phase protection system provides protection for all critical modes in a durable package. The high performance of the Titan 320M allows protection in the worst environments.

Compliant with UL 1449 2nd Edition requirements dated February 9, 2007.



APPLICATIONS

The Titan 320M provides superior design and service life for a wide variety of commercial, industrial or institutional applications. The Titan 320M offers unsurpassed performance and protection for demanding service entrance applications or as part of a complete suppression network. The robust modular construction minimizes possible down time and reduces maintenance costs. The 320M features redundant diagnostic system alerts to ensure uninterrupted protection against harmful transients.

SUPERIOR PERFORMANCE

The Titan 320M utilizes 25 mm MOVs in a high-energy suppression circuit which provides 320,000 peak amps of surge current rating per phase. The 320M utilizes a Sine Wave Tracker suppression circuit for wye configurations which not only provides transient protection but also up to -30 dB noise filtration.

The EFI Electronics Titan 320M provides reliable operation by incorporating EFI's latest improvements. Each surge suppression mode is individually fused and the product is contained in a NEMA 3R/12 metallic housing for maximum performance. The Titan 320M has been tested and is UL and cUL listed.

EASY INSTALLATION

The Titan 320M mounts adjacent to the panel through a conduit connection and as close to the circuit breaker as possible in order to reduce lead lengths and improve protection.

FEATURES	ADVANTAGES	BENEFITS
NEMA 3R/12 ENCLOSURE	Allows installation in outdoor applications	Provides protection to vulnerable equipment powered from weather exposed panels
320,000 AMP CAPACITY	Provides longer service life and protection against high-energy lightning strikes	Keeps valuable electronics safe even in the worst electrical conditions
SINE WAVE TRACKER CIRCUITRY	Increased transient suppression	Improves protection to the equipment
ADVANCED DIAGNOSTICS	Allows for online testing of the suppressors functionality	Allows immediate response if suppressor is damaged
SUPPRESSION STATUS ALARMS	Provides immediate alarm if suppression is ever damaged	Warns if operating with reduced or without protection
THERMAL FUSE	Thermal fuse capable of extreme surge currents	Provides reliable operation and prevents dangerous thermal run-a-way if MOV's are damaged

TITAN® 320M Product Specifications



PERFORMANCE

Surge Current Rating	320 kA/phase
Short Circuit Current Rating	200 kA
EMI/RFI Noise Rejection	Up to -30 dB (wye units)
Sine Wave Tracking Circuit	Yes
Fusing	200 KAIC

MECHANICAL DESCRIPTION

Dimensions	See images
Housing Ratings	NEMA 3R/12
Weight	
w/o disconnect	38.7 lbs (17.6 kg)
w/ disconnect	50.6 lbs (23 kg)

MECHANICAL DESCRIPTION (CONT'D)

Connection Terminals	#10 - #2 AWG
Mounting Method	Parallel
Thermal Fusing	Yes
Operating Frequency	50/60 Hz
Circuit Type	Parallel
Storage Temperature	-40° to +149° F (-40° to +65° C)
Operating Temperature	-40° to +149° F (-40° to +65° C)
Operating Altitude	Sea Level to 12,000 feet (3,658 m.)

WARRANTY

10 years on Product

DIAGNOSTICS

Standard	Push to test Diagnostic Switches, Red & Green Status LED's per Phase (Internal redundant Status LED's per Phase will be Blue for Delta configurations & Green for Wye and Split Phase configurations), Module Status LED's per Mode, Dry Contacts, Audible Alarm with Disable Switch, Surge Counter
Optional	Integral Disconnect, Flush Mount, (for panel size 16"x 20"x 6" only), Remote Monitor

SAFETY AND PERFORMANCE

cUL^{us} 1449 2nd Edition, 2007 requirements, cUL, UL 1283 (wye products only), CSA C22.2 No.8- M1986, IEEE C62.41.1-2002, C62.41.2-2002, C62.45-2002

All Wye and Delta products without disconnects

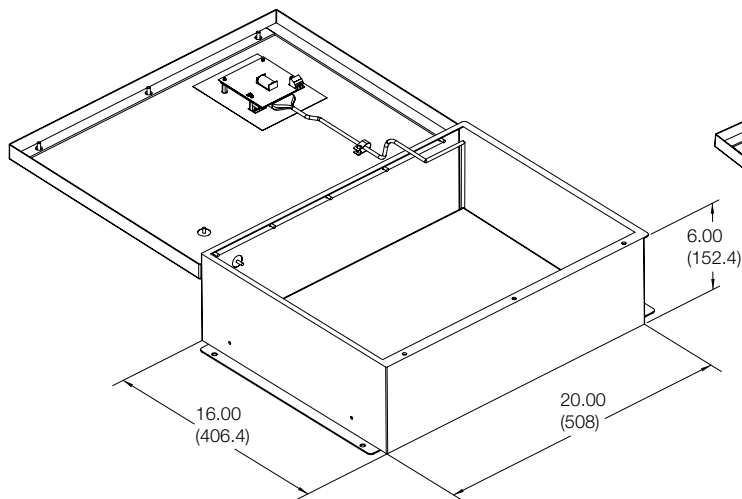

All Wye and Delta products with disconnects

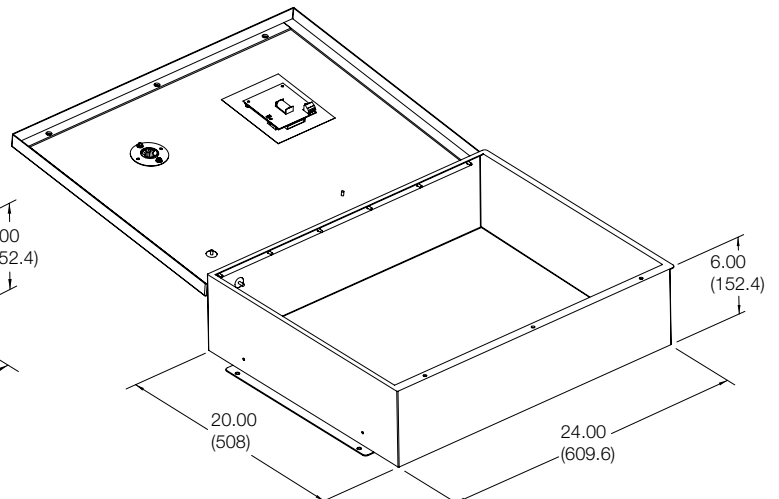

TITAN® 320M Product Specifications



TITAN 320M SYSTEM DESCRIPTION				UL 1449 2-nd EDITION			
Service Voltage	Configuration	Model Number	MCOV	L-N	L-G	N-G	L-L
120/240 wye (Single Phase)	1Ph. Wye 3-wire +G	320M120/240Y	150	400	400	400	800
120/208 wye	3Ph. Wye 4-wire +G	320M120/208Y	150	400	400	400	800
208 delta high resistance ground	3Ph. Wye/Delta 3-wire HRG	320M208HRG	300	N/A	N/A	N/A	900
220/380 wye	3Ph. Wye 4-wire +G	320M220/380Y	320	800	800	800	1500
230/400 wye	3Ph. Wye 4-wire +G	320M230/400Y	320	800	800	800	1500
240/120 delta split phase	3Ph. Delta 4-wire +G 'High Leg'	320M240/120SP	275/150	800/400	800/400	400	1500/800
240 delta corner ground	3Ph. Delta 3-wire Corner Gnd	320M240D	300	N/A	N/A	N/A	900
240 delta ungrounded	3Ph. Delta 3-wire Ungrounded	320M240U	300	N/A	N/A	N/A	900
277/480 wye	3Ph. Wye 4-wire +G	320M277/480Y	320	800	800	800	1500
480 delta high resistance ground	3Ph. Wye/Delta 3-wire HRG	320M480HRG	640	N/A	N/A	N/A	1500
480 delta corner ground	3Ph. Delta 3-wire Corner Gnd	320M480D	640	N/A	N/A	N/A	1500
480 delta ungrounded	3Ph. Delta 3-wire Ungrounded	320M480U	640	N/A	N/A	N/A	1500
347/600 wye	3Ph. Wye 4-wire +G	320M347/600Y	420	1200	1200	1200	2000
600 delta high resistance ground	3Ph. Wye/Delta 3-wire HRG	320M600HRG	840	N/A	N/A	N/A	2000
600 delta corner ground	3Ph. Delta 3-wire Corner Gnd	320M600D	840	N/A	N/A	N/A	2000
600 delta ungrounded	3Ph. Delta 3-wire Ungrounded	320M600U	840	N/A	N/A	N/A	2000

320kA/Phase

NOTE: 320M units come standard with Surge Counter
 When ordering Disconnect Option, add suffix -D to the Model Number. (Ex. 320M120/240Y-D)



ENEDIVSA
 Telefono : 80 04 26 22 Fax Directo : 80 04 26 23
 Correo electronico:ventas@enedivsa.com
 www.enedivsa.com